

**Install guide for (2013-2018 Ram Truck Power Folding Mirrors Package)**

Before you begin, make sure to checkout our install video. We spend a good amount of time getting these videos just right so that they will be a helpful guide.

**Part lists**

- Power Folding Mirror 6x9 or 7x11 (Driver Side)
- Power Folding Mirror 6x9 or 7x11 (Passenger Side)
- Door Module (Driver Side)
- Door Module (Passenger Side)
- Driver Door Controls
- Power Folding Genie Programmer (C-PFM)
- Security Gateway Module Bypass\*
- Tow Mirror reinforcements\*\*



\*Only needed for 2018+ vehicles

\*\*Not Included in Kit - If you're upgrading from 6x9 mirror to the tow 7x11 mirror, and would like Tow Mirror reinforcements, See Step 27.

**Tools required for installation, socket sizes & whatnot.**

- Light Source
- Pry Tool
- Flathead Screwdriver, Philipshead Screwdriver
- T20 Torx Screwdriver
- 10mm Wrench/Socket

**Skill Level:** 3

**Time Investment:** 2-3 hours



**Step 1:** Open the window then remove the plastic trim piece with your pry tool. It is only held in with two retainer clips.



**Step 2:** Around the edge of the door panel, there are six plastic clips that need to be removed. Use your pry tool to remove each plastic clip.



**Step 3:** Next remove the interior door handle. There is a small plastic cover you can pop up with a flathead screw driver.



**Step 4:** You'll see the one philips screw to remove then remove door handle.



**Step 5:** Remove factory door controls. Using your pry tool or a flathead screw driver to pop out the door controls.



**Step 6:** Lift the door controls out and disconnect, place the factory controls off to the side as they will no longer be used.



**Step 7:** You can now lift the door panel out then place it off to the side.



**Step 8:** You'll now see the factory door module. Disconnect all the connections to it.

Note: Take a picture of the connections for your reference.



**Step 9:** There are two T20 screws holding the factory door module in place.



**Step 10:** Remove the factory door module, swap the rubber mat over to new door module.

Note: Each Door Module is labeled with a L for left and R for right.



**Step 11:** Secure new door module in place with the same two T20 screws.



**Step 12:** To remove the factory mirror. You'll need to remove three 10mm nuts. Make sure to support the weight of the mirror when removing the last nut so it doesn't fall.



**Step 13:** Remove the factory mirror and place it off to the side.



**Step 14:** If you are installing Tow Mirror Reinforcements then you will need to install three rivnuts into these three holes.



**Step 15:** Once the rivnuts are installed you can slide the bracket in place then secure with three 10mm screws.



**Step 16:** Take your new mirror and feed the cable into the same hole you took the factory mirror's cable out from.



**Step 17:** Slide the mirror into place and secure in place with at least one nut. Then secure the rest of the three 10mm nuts.



**Step 18:** Tighten down the three 10mm screws and three 10mm nuts.



**Step 19:** Push in the plastic clips to hold down the mirror cable.



**Step 20:** Plug in the factory connectors as well as the power folding mirror connector.



**Step 21:** Time to reassemble the door. Make sure to feed the door controls connector up through its cutout then slide the door panel up over the lock then down into place.



**Step 22:** Plug in the new door controls with the power folding mirror button on it. Then snap it into the door frame.



**Step 23:** Snap back in the door handle frame then secure with the one Philips screw your removed earlier.



**Step 24:** Reinstall the mirror trim panle. You'll hear it snap into place.



**Step 25:** Reinstall all the plastic clips that go around the door panel.



**Step 26:** Repeat the process on the passenger side door. Only difference is you will not be upgrading the door controls, they will stay the same. You will be installing the mirror and right side door module.



**Step 27:** Diagram of where the tow mirror reinforcements are installed.

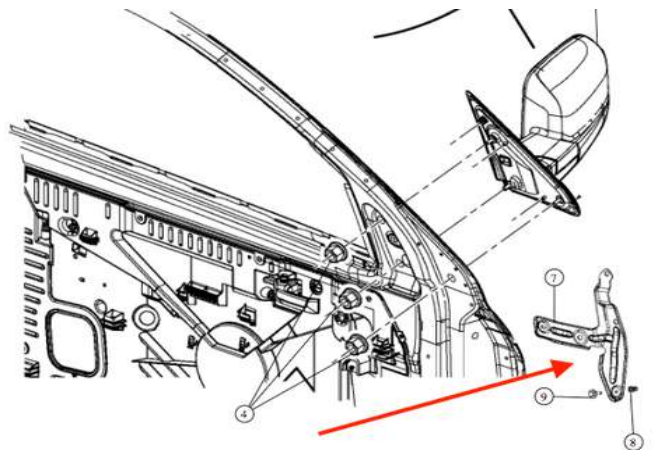

**Step 28:** Here are the part numbers for the tow mirror reinforcement for driver and passenger side plus the nuts and screws used to secure it in place.

7	BRACKET,Trailer Tow Mirror Reinforcement		
	Right,[LEG]	68078242AA	1
	Left,[LEG]	68078243AA	1
8	NUT,Rivet,M6X1.00		
	[LEG]	06507161AA	3
9	SCREW,Hex Head,M6x1x25		
		06508709AA	12

**Step 29:** Install the Security Gateway Module Bypass in the appropriate place. Then proceed with genie programming. This step is only needed for 2018+ vehicles. To find your vehicle's bypass location click the link: [OBD Genie Bypass](#)

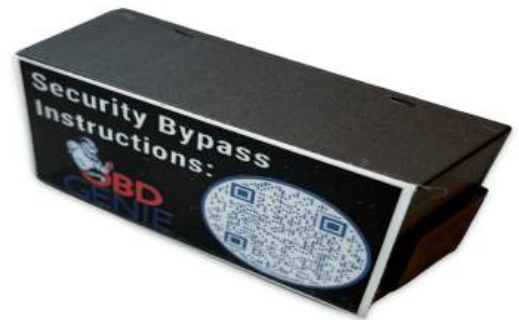

**Step 30:** Use the genie to program the vehicle for the new upgrade.

- I. Put vehicle into the run position.
- II. Wait 1 minute after putting the vehicle into run to plug in the genie programmer.
- III. The genie once plugged in will flash blue as it tries to program.
- IV. The genie will turn a solid green light once programming was completed successfully, programming can take 1-3 minutes long.



V. Remove the genie and give the vehicle a sleep cycle.

VI. Test out your new upgrade.

VII. Enjoy!



**Step 31:** Enjoy your purchase and again thank you for choosing Infotainment.com for your upgrades.



## Return Policy/Warranty Terms

### **Infotainment.com 30-Day Return Policy:**

Infotainment.com offers hassle free returns within 30 days from the date-of-delivery for a full refund unless otherwise stated on the product advertisement (such as a custom or special order item). The customer may choose to cancel their order prior to shipping or fulfillment without penalty. If the customer's order or package sustained physical damage it must be reported to Infotainment.com within 7 days of arrival. A 15% restock fee will apply to all returns unless the returned item(s) have been deemed defective by Infotainment.com after full inspection, in this case a restocking fee will not be assessed.

To initiate a return, the customer is required to contact the customer service department by phone, live chat, or via the online ticket system at anytime within 30 days from the date-of-delivery. The representative will issue a Return Merchandise Authorization (RMA) number, which is required to process your return. A copy of a completed RMA form must be included with the return shipment to expedite the process. The return must be shipped within 7 days of the RMA issuance. Infotainment.com reserves the right to refuse any package returned to them without authorization or process could be delayed over 30 days.

Customers are responsible for all return shipping charges unless they receive the wrong product or a defective item. It is recommended that the customer utilizes signature confirmation and/or insurance when shipping an item to Infotainment.com.

Infotainment.com will not be responsible for lost or damaged packages. Only the signature of an Infotainment.com employee will suffice as proof of delivery. A pre-paid return shipping label may be requested by the customer (located within the continental U.S) at the cost of \$15.00 to be deducted from the total refund amount. Customers located outside the United States will be responsible for all incurred shipping charges and customs duty/tax fees to or from Infotainment.com.

Returns will be processed within ten (10) business days of receipt (not including weekends, holidays, and the day the package is delivered). Refunds will be issued back to the original form of payment. If the original form of payment is no longer valid the refund will be issued as store credit. Infotainment.com reserves the right to reject or impose additional charges for replacement of a return if there is damage, missing



DISCOVER YOUR VEHICLE'S POTENTIAL

components, excessive use/wear, a different serial number from when originally shipped, etc. If the customer's return has not been processed within 3 weeks of arrival the customer is advised to contact the customer service department for an update. This return policy is null & void if product(s) have been tampered with or modified. Infotainment.com is not responsible for professional fees related to installation, removal or re-installation of any product. Infotainment.com reserves the right to change or amend the return policy and procedures at any time without notification.

**Infotainment.com Retail 90-Day Warranty Policy:**

Infotainment.com offers hassle free technical support and warranty claims on all products within 90 days from the date-of-delivery. Physical damage to an item received must be reported within 7 days of arrival.

To initiate a warranty claim, the customer is required to contact the customer service department by phone, live chat, or via the online ticket system at anytime within 90 days from the date-of-delivery. The representative will assist the customer with technical support and step-by-step troubleshooting procedures to resolve any issue or concern. If it is determined that the product(s) must be sent back for repair or exchange the representative will issue a Return Merchandise Authorization (RMA) number, which is required to process the warranty claim. A copy of a completed RMA form must be included with the return shipment to expedite the process. The item(s) must be shipped within 7 days of the RMA issuance. Infotainment.com reserves the right to refuse any package returned to them without authorization or process could be delayed over 30 days.

A pre-paid return shipping label will be issued by the customer service representative for customers located within the continental U.S. only. Customers located outside the U.S. will be responsible for all incurred shipping charges and customs duty/tax fees to or from Infotainment.com. Customers are fully responsible to ensure the item(s) are packaged securely to prevent damage in shipping transit. Infotainment.com will not be responsible for damaged item(s) due to poor packaging.

Warranty claims will be processed within five (5) business days of receipt (not including weekends, holidays, and the day the package is delivered). An Infotainment.com technician reserves the right to determine whether the troubled product requires a simple repair or a full replacement. Once the issue is resolved, a tracking number will be immediately provided to the customer when the repaired or replacement item is shipped



DISCOVER YOUR VEHICLE'S POTENTIAL

therefore ending the warranty claim. Infotainment.com reserves the right to reject or impose additional charges for warranty claims if there is damage, missing components, excessive use/wear, a different serial number from when originally shipped, etc. Infotainment.com will allow up to two (2) claims per order before it is determined the item(s) will not work in the customer's vehicle. If the customer's warranty claim has not been processed within 3 weeks of arrival the customer is advised to contact the customer service department for an update.

This warranty policy is null & void if product(s) have been tampered with or modified. Infotainment.com is not responsible for professional fees related to installation, removal or re-installation of any product. Infotainment.com reserves the right to change or amend the warranty policy and procedures at any time without notification.

**Infotainment.com Extended 1-Year Warranty Policy:**

Infotainment.com offers hassle free technical support and warranty claims on all products within 1 year from the date-of-delivery to retail customers who opt for the extended warranty coverage upon checkout. This policy also applies to all registered Infotainment.com wholesale accounts. Furthermore, franchise automobile dealers are granted additional coverage for their customers to match the vehicle's 3 year / 36,000 mile bumper-to-bumper manufacturer's warranty.

To initiate a warranty claim, the customer is required to contact the customer service department by phone, live chat, or via the online ticket system at anytime within 1 year from the date-of-delivery. The representative will assist the customer with technical support and step-by-step troubleshooting procedures to resolve any issue or concern. If it is determined that the product(s) must be sent back for repair or exchange the representative will issue a Return Merchandise Authorization (RMA) number, which is required to process the warranty claim. A copy of a completed RMA form must be included with the return shipment to expedite the process. The item(s) must be shipped within 7 days of the RMA issuance. Infotainment.com reserves the right to refuse any package returned to them without authorization or process could be delayed over 30 days.

A pre-paid return shipping label will be issued by the customer service representative for customers located within the continental U.S. only. Customers located outside the U.S. will be responsible for all incurred shipping charges and customs duty/tax fees to or from Infotainment.com. Customers are fully responsible to ensure the item(s) are



DISCOVER YOUR VEHICLE'S POTENTIAL

packaged securely to prevent damage in shipping transit. Infotainment.com will not be responsible for damaged item(s) due to poor packaging.

Warranty claims will be processed within five (5) business days of receipt (not including weekends, holidays, and the day the package is delivered). An Infotainment.com technician reserves the right to determine whether the troubled product requires a simple repair or a full replacement. Once the issue is resolved, a tracking number will be immediately provided to the customer when the repaired or replacement item is shipped therefore ending the warranty claim. Infotainment.com reserves the right to reject or impose additional charges for warranty claims if there is damage, missing components, excessive use/wear, a different serial number from when originally shipped, etc. Infotainment.com will allow up to two (2) claims per order before it is determined the item(s) will not work in the customer's vehicle. If the customer's warranty claim has not been processed within 3 weeks of arrival the customer is advised to contact the customer service department for an update.

This warranty policy is null & void if product(s) have been tampered with or modified. Infotainment.com is not responsible for professional fees related to installation, removal or re-installation of any product. Infotainment.com reserves the right to change or amend the warranty policy and procedures at any time without notification.